



ES & HU Installation, Operation and Maintenance Manual

PUR 101137 REV 5.18

439 Main Road, Towaco, New Jersey 07082

(718) 386-6666 • 1-800-221-1522

sussmanboilers.com • Email: seb@sussmancorp.com

Model No. _____
 Boiler Serial No. _____
 National Board No. _____
 Safety Valve Set Pressure _____ PSIG
 Power Circuit Voltage _____
 Control Circuit Voltage _____
 Amps _____ Phase _____ HZ _____
 Steam Outlet Valve Size _____ NPT

Products covered by this manual:

Series	KW Range	Max Steam Rate*	BHP	Design Pressure	Work Pressure
ES, HU	12-180	36-542 lbs/hr	1.2-18.4	0-100 psig	85 psig

*Steam Rate: Steam at 212°F with 50°F feed water

ES and HU boilers are of Carbon Steel construction. See page 23 for Water Quality Information.

TABLE OF CONTENTS

Dimensional Information and Component Identification 3
 Dimensional & Clearing Specifications 4
 Wiring Diagram 5
 Installation 6
 Piping 6
 Wiring 7
 Pre-Operation Check 8
 Setting Pressure Controls 9
 Operation 10
 Blowdown 10-11
 Digital Timer Operation Instructions 12
 Timing Switch 13
 Maintenance 13
 Standard Equipment
 Auxiliary Low Water Cut Off 14
 Line Pressure Water Feed System 14
 Optional Equipment
 High Pressure Water Feed System 14
 Condensate Return System 14
 Vacuum Breaker Systems 15
 Automatic Blowdown System 15
 Control Voltage Stepdown Transformer 15
 Blowdown Separators 15
 Multistage Load Progressive Sequencers 15
 Condensate Return Systems 16
 Blowdown Separator Tanks 17
 Specification Charts 18
 Sizing 19
 Gauge Glass Installation 20-21
 Element Replacement 22
 Water Quality Information 23

IMPORTANT NOTE:

As you follow these instructions, you will notice warning and caution symbols. This blocked information is important for the safe and efficient installation and operation of electric boilers. These are two types of potential hazards that may occur during this installation and operation:

 **WARNING** states a hazard which may cause serious injury or death if precautions are not followed.

 **CAUTION** signals a situation where minor injury or product damage may occur if you do not follow instructions.

IMPORTANT NOTE:

This highlights information that is especially relevant to a problem-free installation.



Dimensional Information & Component Identification

Models: ES, HU

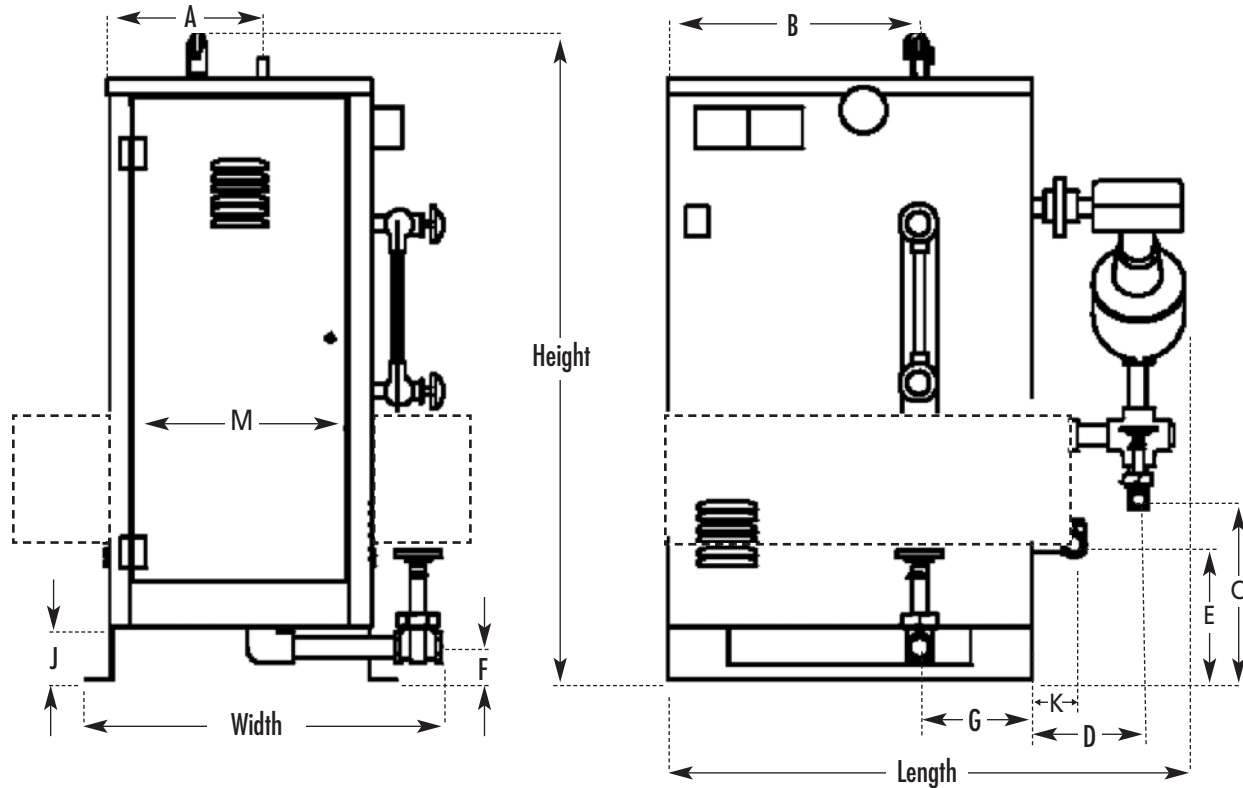

SYMBOL	ITEM	ES12-18 HU40-55	ES24-72 HU75-205	ES85-100 HU310	ES135-180 HU410-550
Height	Overall Height	36"	46"	61"	61"
Length	Overall Length	28"	33"	34"	36"
Width	Overall Width	22"	22"	25"*	27"**
A	Steam Outlet	6-1/4"	10"	8-1/4"	9"
B	Steam Outlet	10-1/4"	17"	17-1/4"	18-1/4"
C	M/M Drain Valve	5"	12"	17"	16-3/4"
D	M/M Drain Valve	6-1/2"	6"	6-1/4"	6-1/4"
E	Check Valve	14"	9"	17"	16-3/4"
F	PV Drain Valve	2-3/4"	2-1/4"	2-3/4"	2-3/4"
G	PV Drain Valve	6-1/4"	9-1/2"	7-3/4"	9-1/4"
J	Clearance	3-3/4"	3-1/2"	4"	4"
K	Check Valve	2-1/2"	2-3/4"	3"	3"
M	Door Width	8-3/4"	14"	12-3/4"	14-3/4"

MODEL	Steam Outlet		Safety Valve Outlet	
	100 PSIG	15 PSIG	100 PSIG	15 PSIG
ES12-18, HU40-55	1/2" NPT	1/2" NPT	1/2" NPT	3/4" NPT
ES24-36, HU75-105	1" NPT	1" NPT	1/2" NPT	3/4" NPT
ES48, HU140	1" NPT	1" NPT	1" NPT	3/4" NPT
ES60-72, HU175-205	1" NPT	1" NPT	1" NPT	1" NPT
ES85-100, HU310	1 1/2" NPT	3" NPT	1" NPT	1 1/4" NPT
ES135-180, HU410-550	2" NPT	3" NPT	1" NPT	1 1/2" NPT

Water inlets for all ES & HU boilers are 1/2" NPT
Drains for all ES and HU boilers are 1" NPT

Allow minimum 36 inches clearance in front of doors for servicing of heating elements.
Recommended clearance: 24 inches other sides of boiler for servicing.

* ES100 Width shown is for 480 volts with one front mount fuse box, 208/240 volt that includes a front and back mounted fuse box is 30" wide

** ES135 -180 Width shown is for 480 volts with one front mount fuse box, 208/240 volt that includes a front and back mounted fuse box is 32" wide

All 480 volt ES100-180 include a front mounted box for fuses (shown as dotted lines)

All 208 and 240 Volt ES100-180 include a front and back mounted box for fuses (shown as dotted lines)

ES72 208 Volt includes a front mounted fuse box, overall width increases to 24"

Dimensional & Clearance Specifications

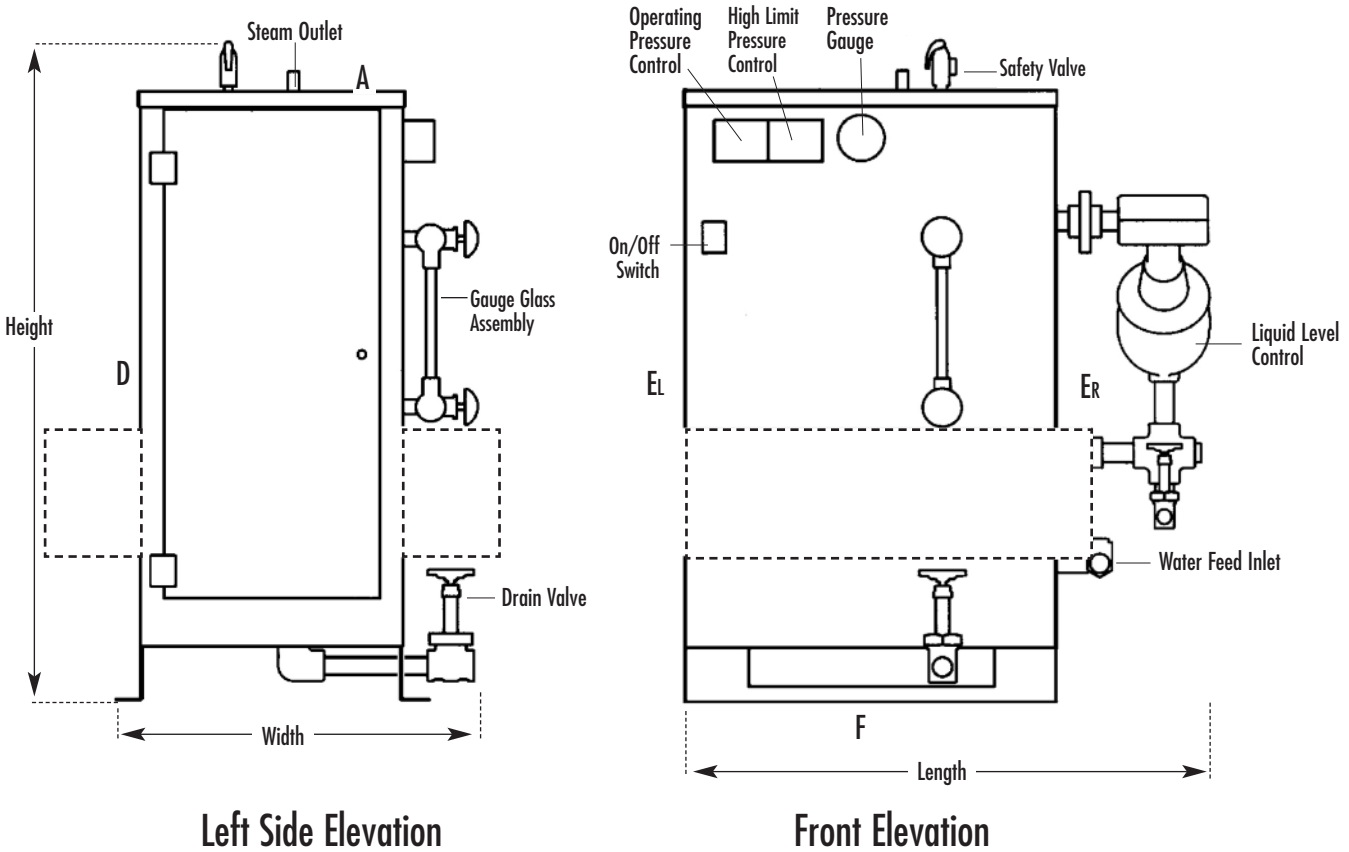

Allow 24" all around for servicing, 36" in front of doors, minimum.

Clearance from combustible surfaces		
A	1"	Clearance above top of boiler
B	A	Clearance from Front of boiler. Prefix "C" to numeral indicates acceptability for closet or alcove installations; prefix acceptability for alcove installations but not for closet installations.
D	1"	Clearance from back of boiler.
EL	1"	Clearance from left side of boiler.
ER	16"	Clearance from right side of boiler.
F	C	Indicates type of flooring: "NC" for non-combustible; "C" for combustible.
G	-	Total minimum free area in square inches of close ventilating openings.

All 480 volt ES100 - 180 include a front mounted box for fuses (shown as dotted lines)
 All 208 and 240 Volt ES100 - 180 include a front and back mounted box for fuses (shown as dotted lines)
 ES72 208 Volt includes a front mounted fuse box.

Wiring Diagram

Power Circuit and Control Circuit use different voltage

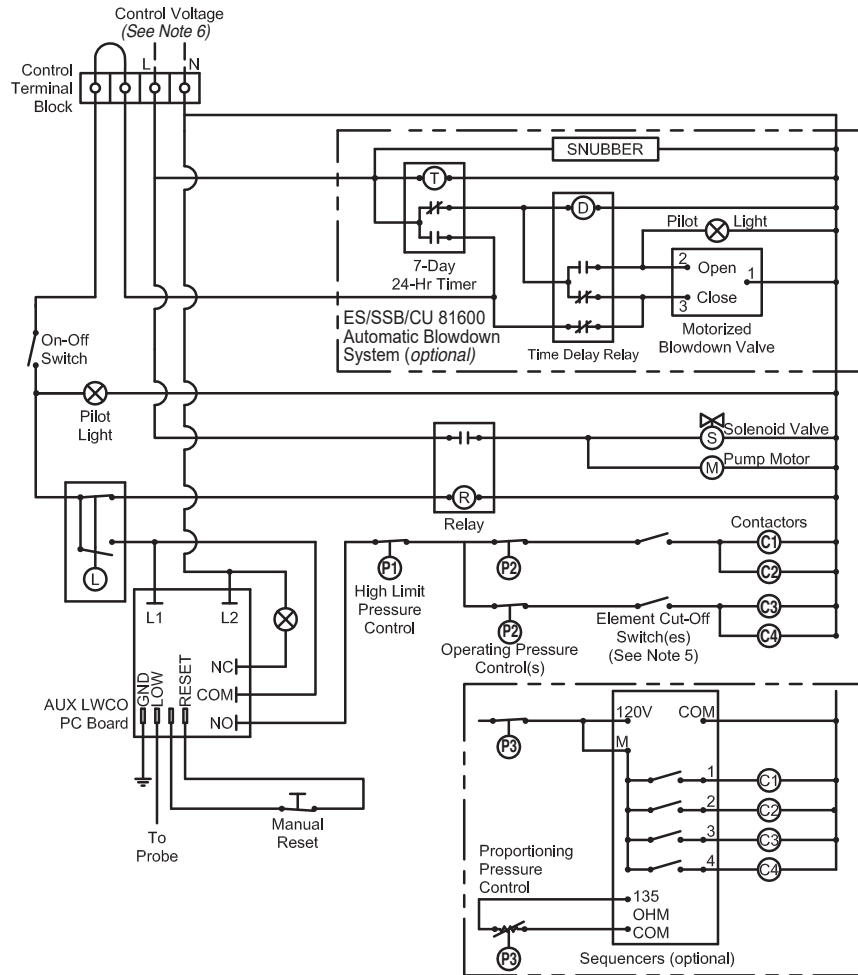

Three Phase Main Power Supply

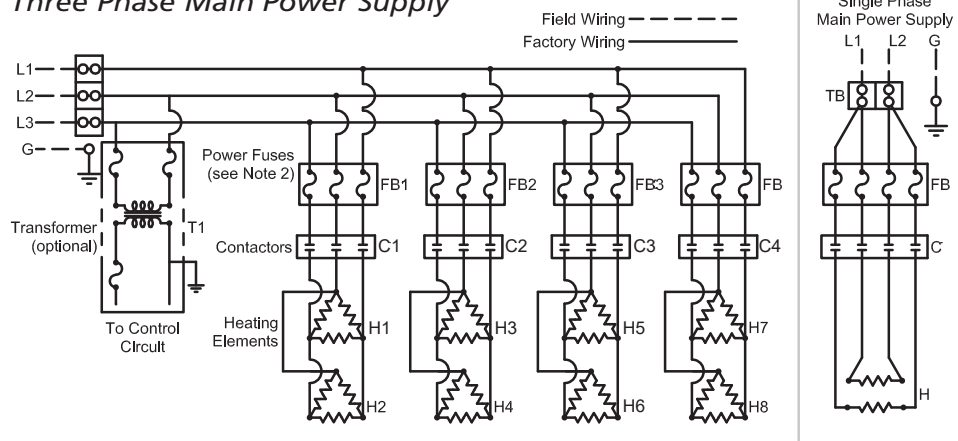

NOTES:

1. Power Terminal Block only on boilers with two or more contactors.
2. On boilers with only one power contactor, connect power voltage to line side of contactor.
3. Power Fuses only on boilers rated 120 amperes and larger.
4. See Parts List for contactor and heating element information.
5. Element cut-off switches and second operating pressure control on ES/SSB 100-180 without sequencer
6. Refer to boiler nameplate for control and main power voltage

Installation

REFER TO NATIONAL AND ALL APPLICABLE LOCAL CODES FOR SPECIFIC INSTALLATION REQUIREMENTS.

1. The boiler should be mounted on a solid, level foundation.
2. The boiler should be located with suitable clearances, refer to page 3 and Code requirements.

NOTE: Allow a minimum of 36 inches clearance in front of doors for servicing of heating elements. Recommended clearance: 24 inches other sides of boiler for servicing.

3. Do not install boiler in any location where water could freeze.
4. Do not install boiler outdoors.
5. Do not install boiler near flammable or corrosive materials.
6. Do not install boiler in a location where leakage from the boiler tank or piping can damage to adjacent areas or to lower floors of the structure. Provide a floor drain and properly sloped floor from the boiler towards the drain or install a suitably plumbed drain pan under the boiler.

Piping

ALL PIPING SHOULD BE INSTALLED BY A QUALIFIED LICENSED PLUMBER IN ACCORDANCE WITH NATIONAL AND LOCAL CODES.

1. When water feed is other than pump type the water supply pressure must be 10 psig greater than boiler operating pressure to assure water supply maintains proper water level in the boiler. Insufficient water levels can result in improper boiler operation. (Keep feed water valves open at all times during normal operation.)
2. Connect steam line with a valve to boiler steam outlet

NOTE: For best performance, a valve rated for steam service higher than the maximum boiler pressure should be plumbed on the steam outlet line; failure to do so can cause heating element breakdown. See page 3 for steam outlet valve size.

4. Provide for boiler drain connection, a daily blowdown is required. A "Blowdown Separator Tank" may be necessary, check with local code.
5. Safety valve shall be plumbed according to local code.

NOTE: The safety valve shall not be plumbed with a line sized less than the outlet size of the safety valve.

Wiring

ALL ELECTRICAL WIRING MUST BE PERFORMED BY A QUALIFIED ELECTRICIAN IN ACCORDANCE WITH NATIONAL AND LOCAL ELECTRICAL CODES.

⚠ CAUTION Assure that the power voltage and phase being supplied to the boiler matches the power voltage and phase of the boiler. Connecting incorrect power supply can damage boiler components or cause improper boiler operation. If the boiler power requirements do not match the power to be supplied to the boiler the boiler must be returned to the factory for conversion. Boilers cannot be field converted.

ALL BOILERS ARE PRE-WIRED AND TESTED PRIOR TO SHIPMENT.

1. Ground boiler according to National Electric Code requirements to avoid shock.
2. Power wiring to boiler should be in accordance with National and Local Electrical Code requirements following wiring diagram supplied. Use proper size wire. Wire size is specified adjacent to field wiring terminals. This label states the wire size [AWG or MCM], minimum temperature rating (90 C) and conductor material (copper only). Deviation from these requirements may result in improper or unsafe boiler operation.
3. A disconnect switch employing circuit breakers or fuses should be installed between the main power source and the boiler. This disconnect switch should be located near the boiler and clearly marked for easy access and identification should the boiler need to be turned off due to an emergency.
4. Boiler control circuit is 120 Volt*. Unless boiler has an optional step down transformer, a separate 120 Volt power feed wiring is required to be connected to the control circuit terminal block. A 15 Amp circuit is required for all boilers. If a 3/4 HP feed water motor and pump assembly is connected to the boiler, then a 20 Amp circuit is required.
5. If a separate control circuit is used, it should be connected to the control circuit terminal block.
6. Remote mounted water feed systems (i.e. condensate return, motor and pump) should be connected to the junction box provided on the outside of the boiler jacket.
7. With main power off, make sure all wiring terminations are tight to avoid arcing, carbonizing or overheating of contacts.

⚠ CAUTION Boilers are susceptible to lightning damage due to water line connections. An industrial type lightning/surge protector should be installed according to the manufacturer's recommendation at the service entrance. Consult your contractor or electrical dealer.

⚠ WARNING Substitution of components or modification of wiring system voids the warranty and may lead to dangerous operating conditions.

Pre-Operation Check (All Boilers)

LWCO/PUMP CONTROL OPERATION AND TESTING

1. All valves for incoming water supply are to be fully opened. Main disconnect switch is to be in the "on" position. Boiler main switch is to be in the "on" position. Since boiler will be empty the pump or solenoid will be energized allowing the boiler to fill with water. Control will automatically fill boiler to proper operating water level and the pump/solenoid will be de-energized. Contactors will then energize, applying voltage to the heating elements.
2. Pump switch operation – at this point water should be visible approximately half way up the sight glass. Slowly open the drain valve located at the bottom of the boiler. Water level in the sight glass will begin to drop, allowing the low water cut off/pump control to energize the feed water system. Close valve for proper operation.
3. Low water cutout switch performance – open the drain valve completely. Maintain this condition until water level falls within the gauge glass enough to cause the low water cutout switch to de-energize the heating elements. All of the contactors will be in a de-energized or open state at this time. Close the drain valve, water feed system will automatically refill the boiler and the contactors will re-energize.

Boilers equipped with an auxiliary low water cut-off control with a manual re-set button (required as mandatory equipment in some states): once the correct operating water level has been reached, it will be necessary to depress the reset button in order for the contactors to re-energize.

NOTE: For boilers equipped with an automatic blow-down system:

- **For test 1** - the blowdown time clock must be in the "run" mode before the boiler will automatically fill.
- **For test 2 and 3** - in order for the drain valve to open the blowdown clock must be in the "off" mode. (See blowdown time clock insert) The automatic blowdown indicator light will be on when the valve is open. This light will remain on for the duration of the blowdown cycle (a few seconds). It may be necessary to cycle the time clock from the "run" to "off" mode several times.

Pressure Controls, Operation and Testing

NOTE: All boilers are provided with one high limit pressure control and at least one operating pressure control.

1. The high limit pressure control is equipped with a manual reset feature. There is no subtractive differential scale with this type of control
2. All pressure controls are equipped with an adjusting screw, allowing for setting of desired operational and high limit pressures. To reduce pressure setting, turn adjusting screw in direction that allows indicator to point to a lower pressure setting on the scale. To increase pressure setting turn adjusting screw in direction that allows indicator to point to a higher pressure on the scale

NOTE: It is recommended that the high limit control be set 10% above the desired normal operating pressure (15 psig boilers should be set to 13 psig)

3. Operating pressure controls, except low pressure (15 psig) types have a separate differential scale. Differential indicates pressure below the main operating maximum pressure, the pressure control will re-set. The differential set point is adjusted in the same manner by turning the adjusting screw in the desired direction to increase or decrease the differential pressure value.
4. Operating pressure control check: Close steam outlet valve [supplied by customer] and adjust operating pressure

control to 20 psig (10 psig for low pressure boilers) and the differential to 10 psig (**Note:** Low pressure boilers do not have a differential setting). Set the high limit pressure control to 30 psig (13 psig for low pressure boilers). Switch boiler on to allow steam pressure to build-up. Pressure gauge reading will increase and the operating pressure control will de-energize the contactor(s) when the pressure gauge indicates 20 psig (10 psig for low pressure boilers). Open steam outlet valve to bleed off pressure. When the pressure gauge reading decreases below 10 psig (differential) (3 psig for low pressure boilers) the operating pressure control will re-energize the contactor(s).

5. High limit pressure control check: **FOR TEST PURPOSES ONLY!** Set the high limit pressure control 10 psig (5 psig for low pressure boilers) lower than the operating pressure control. Close the steam outlet valve and switch the boiler on to allow boiler to build pressure. When the pressure gauge indicates the pressure at which the high limit pressure control is set, the high limit pressure control re-set button will pop-up and the control will de-energize the contactor(s). Open the steam outlet valve to bleed off pressure. The contactor(s) should not re-energize on pressure drop. The contactor(s) should only re-energize when the pressure has dropped and the high limit pressure control reset button is depressed.

Setting Pressure Controls

1. To set the controls turn the operating pressure controller to its highest setting
2. Using the pressure gauge on the boiler adjust the high limit pressure controller to the desired set point. This is done by starting the boiler and having it build pressure to desired set point (as shown on the boiler pressure gauge).
3. Once the desired set point (always set the high limit pressure controller to at least 10% above the required operating pressure) is reached, turn the power off of the boiler and isolate the boiler by closing the steam outlet valve.
4. Proceed to lower the high limit pressure control set point until the high limit reset switch pops up.
5. Once the high limit control is set proceed to set the operating pressure control in the same way as the high pressure was set as outlined in steps 2-4. There is no reset button on the operating controller so you will have to listen for a click.
6. Once the operating pressure controller is set you will need to set the differential pressure (not applicable for the 15 psi model as the default differential is set to 3 psi). The differential is set by bringing the boiler up to pressure and tripping the operating pressure controller then slowly letting down the pressure. When the operating pressure controller clicks back in that is where the differential is set. Between these two points is where the boiler will operate. The smaller the differential is the more the boiler will cycle on and off and the larger the differential the wider the pressure swings will be.

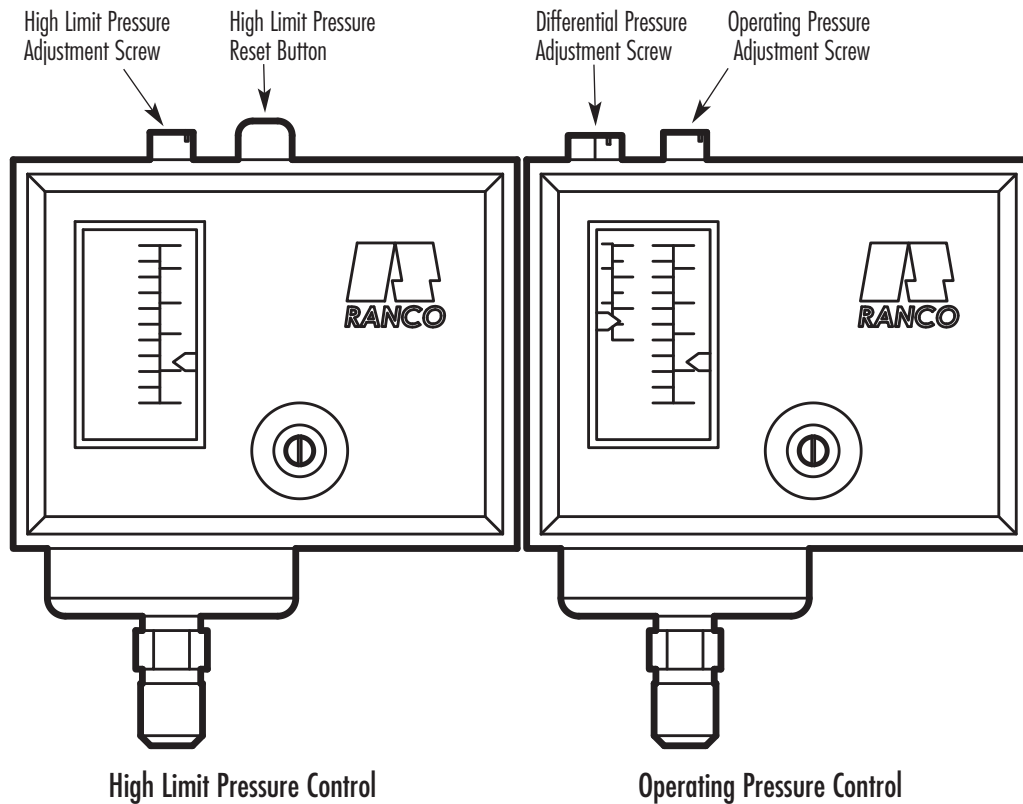

Operation

 **CAUTION** With main disconnect "OFF" tighten all electrical connections before energizing boiler to prevent arcing, carbonizing of contact and/or overheating

1. Set the desired operating pressure and differential pressure on the operating pressure control.
2. Set the high limit pressure control. (Recommended to be 10 psig above the operating pressure setting.)
3. Turn on water supply.
4. Turn main disconnect switch on.
5. Turn boiler control switch on. The water feed will begin and continue until the water level reaches half way up the gauge glass. The water feed will automatically shut off and the contactor(s) will energize.
6. Boiler steam pressure will gradually increase to the operating pressure control set point, at which time the contactor(s) will de-energize.

7. With steam demand, the boiler steam pressure will decrease. When the boiler pressure has dropped below the operating pressure control differential set amount, the contactor(s) will re-energize.

NOTE: Adjust steam outlet valve such that the boiler pressure does not drop more than 20% below reset.

8. The boiler is equipped with float type liquid level controls employing micro switches. They are extremely sensitive and reliable and will maintain the proper water level within the boiler pressure vessel automatically during boiler operation.
9. The boiler should be blown down daily. (See blowdown instructions.)

Blowdown

A daily blowdown is an essential part of boiler operation. It is the best and most important part of preventative maintenance you can give your boiler and will add years of life to the unit. Make sure a blowdown schedule is established and followed regularly.

In extremely hard water areas, blowdown may be necessary more than once a day. If there is a particular problem that applies to your local water condition (i.e. high concentrations of minerals etc.) we recommend a consultation with a reputable local water treatment-engineering firm. Pre-treating the boiler feed water may reduce mineral accumulation enough to allow a daily blowdown to be sufficient.

MANUAL BLOWDOWN INSTRUCTIONS

1. At the end of the working day, while boiler is still operating, turn boiler main switch to the "OFF" position, close water supply valve and open disconnect switch.
2. If blow down valve is plumbed into a blowdown tank, the boiler can be discharged at operating pressure.
3. If the blowdown valve is not plumbed into a blowdown tank, consult with local plumbing codes regarding boiler discharge.
4. When discharge is complete and boiler is drained, close the blowdown valve, open the water supply valve, turn boiler main switch to "ON" position and close disconnect switch.
5. When refilling is complete, turn off the boiler unless further operation is needed.
6. If boiler is equipped with a "Manual Re-set Auxiliary Low Water Cut-off" (as required in some states) the re-set button must be pushed before the boiler will begin developing steam. Do not push re-set button until the boiler has refilled with water.

Blowdown (cont.)

AUTOMATIC BLOWDOWN INSTRUCTIONS

(PN ES81600) 1" NPT, Starts, stops and blows down the boiler automatically, utilizing a programmable time clock a time-delay relay and motorized ball valve.

CAUTION If the blowdown valve is plumbed into a blowdown tank, the boiler can be discharged at operating pressure. If the blowdown valve is not plumbed into a blowdown tank, consult with local plumbing codes regarding boiler discharge.

NOTE: The manual valves from the boiler drain and the lower float control equalization tube must be fully open for the automatic blowdown to be effective.

1. Program time clock by setting the time boiler is to turn on and off daily. (Refer to instructions in time clock insert.)
2. When the time clock turns the boiler "off" the blowdown is activated. A red pilot light over the time clock will come on and remain on while the motorized ball valve is open. The time duration the valve is open is set by an adjustable potentiometer built into the time delay board. The water level in the boiler after blowdown is complete, will be approximately at the lower gauge glass valve. (Elements are not exposed to air between operations.)
3. Boiler will automatically refill at next programmed on cycle.

Blowdown program can be overridden to allow for unscheduled blowdown or operational cycles. Refer to the time clock instruction insert.

DURATION ADJUSTMENT INSTRUCTIONS

WARNING Hazard of Electric Shock. Disconnect all power supplies before making any adjustments

Using a small flathead screwdriver, rotate the adjustment screw to the desired setting.

IMPORTANT: Do not set less than 10 seconds. Do not force screw past min and max stops, screw does not rotate more than 300 degrees

FACTORY RECOMMENDED SETTINGS:

- 100 psig Trim: 50% turn (shown, 30 seconds)
- 15 psig Trim: 100% turn (shown, 60 seconds)

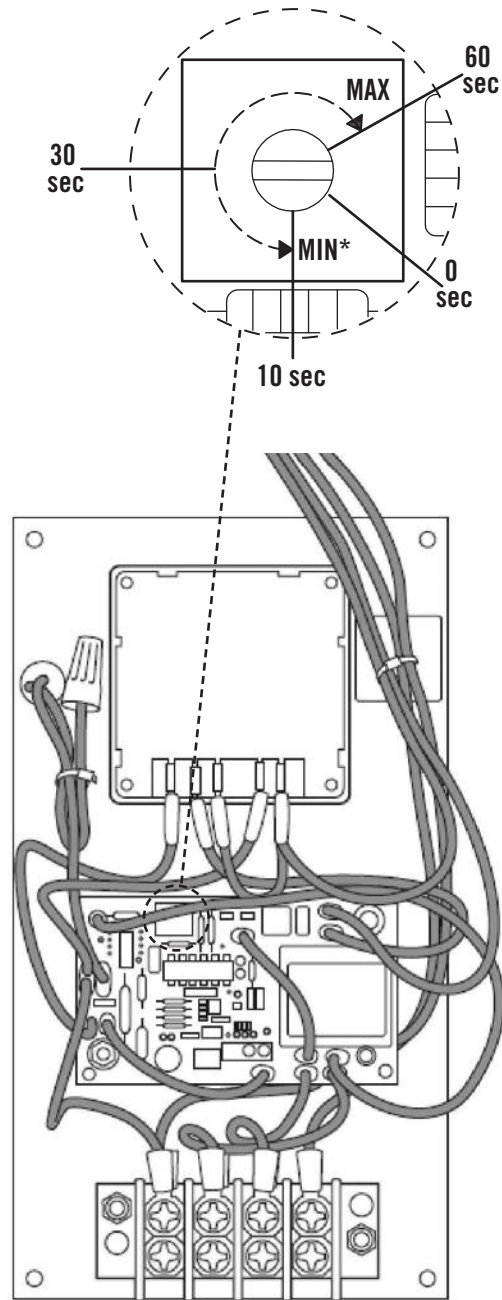

Back

Digital Timer - Operation Instructions

TO SET TIME & DAY OF CLOCK

1. Hold down the image of clock button ⌚ for steps 2-4
2. Press the "Day" button to cycle through the days which are listed on the top line
3. Press the "h+" button to increase the current hour.
Note: this will also change the **AM/PM** as it is listed to the right of the minutes.
4. Press the "m+" button to increase the current minute.

TO SET TIMER ON/OFF TIMES

(there are 7 different programs that can be set)

5. Click the "Timer" button to go into the timer mode.
6. **Program 1 ON** will be the first to come up.
This will be when the boiler turns on.
Set the day and time the same way you set the timer in steps 2-4.
7. Hit the "Timer" button to save the entry and move onto the next setting.
8. The next setting will be **Program 1 OFF**.
This will be when the boiler turns off. Once the boiler is turned off the automatic blowdown system will activate. Follow steps 2-4 to set the date and time. Hit the "Timer" button to save the settings.
9. Repeat steps 6-8 to set programs 2-7.

ON/OFF STATUS:

Pressing the image of a hand with a pointed finger button (👉) changes the current mode of the timer. If **ON** is indicated on the display the boiler is currently running and if **OFF** is indicated the boiler is off/blowing down. Once one of the programs are started the indicator will automatically turn to the **ON** position and when one of the programs ends it will automatically be set to the **OFF** position.



DAYLIGHT SAVING TIME:

The timer does not automatically adjust for daylight saving time and the time will have to be adjusted manually.

PROGRAMMED COMBINATIONS:

Switch **OFF** commands have priority over switch **ON** commands.

NOTES:

1. The timer is set according to the boiler operation.
When the timer is **ON** the boiler is **ON** and the blowdown is **OFF**.
2. During programming, if no button is pressed after 30 seconds, the timer will revert back to normal operating mode.
3. After programming, the override button (👉) may need to be pressed to change the **ON/OFF** status for the current day and time.

Mechanical Timer

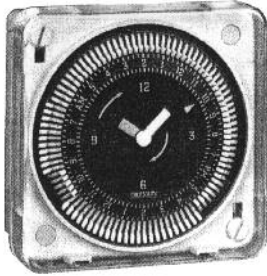

PROGRAMMING

For electric steam boilers equipped with Automatic Blowdown Systems ES 81600, refer to the following instructions for time clock operation and settings.

Timer settings for blowdown operation are at the discretion of the owner/operator.

The weekly program dial shows the seven days of the week and AM/PM imprints for each day.

The time switch is set by pushing the captive trippers to the outer ring position for the entire period that the load is to be turned ON, i.e., 2 hours to each tripper on the 7-day dial. When the tripper is pushed to the inside, the switch is in the OFF position.

SETTING TIME

To set the current time and day of week, turn the minute hand clockwise. Do not set the time by rotating "Outer" Dial.

Turn the minute hand clockwise until the day of the week and the time of day on the outer dial is aligned with the triangle marker on the inner dial (two o'clock).

Example for 7-day program dial Monday 10:30 AM. Turn the minute hand clockwise until Monday 10:30 AM is aligned with the triangle on the inner dial. The hour and minute hand will show exactly 10:30.

FOR MANUAL OVERRIDE

Manual override can be accomplished at the discretion of the owner/operator as follows.

3-WAY MANUAL OVERRIDE SWITCH

- I = permanent ON
- ⊖ = automatic
- O = permanent OFF



IMPORTANT: It is recommended that for periodic and effective blowdown, the override switch be set in the ⊖ automatic setting.

Maintenance

CAUTION HAZARD OF ELECTRIC SHOCK. DISCONNECT ALL ELECTRICAL POWER BEFORE WORKING ON BOILER.

Sussman Electric Steam Boilers are designed for years of trouble-free performance. To establish a good preventative maintenance program, we suggest that the facility maintenance person or engineer familiarize themselves with these simple rules.

1. Daily blowdown at pressure is essential for ideal boiler performance. Extended periods of operation may require more frequent blowdown. If the boiler is not equipped with an automatic blowdown, in order to safeguard the heating elements, it is recommended to turn both the main disconnect switch and the boiler switch to the off position before manually blowing down the boiler.
2. The sight glass should be checked frequently to assure the boiler has adequate water.
3. The sight glass should be checked daily for damage (i.e. scratches, erosion, leaks etc.) The sight glass should be replaced if damaged. (See insert.)
4. A monthly inspection should be made of the internal wiring. Open the access door and check all electrical connections for tightness. Replace any wires that show signs of damage.

NOTE: The electrical power MUST be shut off during this maintenance procedure.

5. Heating element mounting bolts should be checked and tightened to a torque of 22 ft.-lbs. If there are indications of steam leaks from an element, replace the element gasket.
6. A monthly check for leaks should be made; any loose or damaged fittings should be tightened or replaced.
7. Every four months the boiler float control should be checked for proper operation. The lower equalization column can be examined visually and manually to see if is clear and clean. If there are signs of scale or mineral deposit buildup the float control must be disassembled and cleaned.

One of the lower heating elements should be removed. If scale or mineral deposits have begun to form all elements should be removed cleaned and reinstalled using new element gaskets.

Operating and high limit pressure control operation should be checked. Pressure controls should be removed and cleaned if necessary. Water feed supply check valves should be inspected and replaced if necessary.

8. If the boiler is equipped with an electronic auxiliary low water cut-off every four months the probe should be removed and checked for deposits. The probe should be cleaned and reinstalled.

Standard Equipment for ES & HU

AUXILIARY LOW WATER CUT OFF

- For model ES & HU boilers PN ES81017MR (with manual reset).

Senses water level electronically using a resistance probe. When a low water condition is detected, the contactor control voltage circuit is interrupted and the heating elements are de-energized. When water level returns to proper levels voltage is restored to the contactor coils and the elements are re-energized. For controls with a manual reset button voltage to the contactor coils is not restored until the water level has returned to proper operating levels and the reset button is pushed. Do not depress the reset button before the correct water level is achieved.

To test AUX LWCO, press and hold the manual reset button on the side of the boiler for 5 seconds.

A blinking light on the PC board indicates the board is having difficulty sensing water (either due to a dirty probe or low conductivity in the water). Holding the reset button for 30 seconds should reset the board back to function. See next section for maintenance schedule in locales where water quality requires regular treatment.

LINE PRESSURE WATER FEED SYSTEM

- For model ES & HU boilers PN ES99117

Water feed system used to supply makeup water to the boiler when incoming water line pressure is 10 psig greater than the operating pressure of the boiler. Completely factory plumbed and wired; 0-100 psig range; 1/2" NPT size. Consists of strainer, solenoid valve (120/1/50-60Hz), and check valve for automatic feed.

Optional Equipment

HIGH PRESSURE WATER FEED SYSTEM

- For model ES12-72 PN ES38002A
- For model ES100-180 PN ES38020A
Used to supply makeup water and to maintain constant water level when the boiler operating pressure is equal to or greater than incoming water line pressure and condensate is not returned to the boiler.
- ES38002A – Range is 0 – 100 psig, 1/2" NPT size consisting of strainer, solenoid valve and 1/3 HP 120/1/60 motor and pump.
- ES38020A – Range is 0 – 125 psig, 3/4" NPT size consisting of strainer solenoid valve and 1/2 HP 120/1/60 motor and pump.
These assemblies are mounted on rubber shocks and secured to a steel base mounting plate. These units require field plumbing and wiring to the boiler.

CONDENSATE RETURN SYSTEM (see page 16)

- For model ES12-72 PN ES38083V; for model ES85-180 PN ES38084V.
These systems are used whenever condensed steam can be collected for reuse in the boiler. Returning the condensate to the boiler can save a significant amount of energy. The water returned is relatively free of corrosive minerals and carries a substantial amount of heat that does not have to be replenished. A vacuum breaker is required whenever a condensate return system is used.
Each system consists of a vertical condensate return tank, a motor and pump and support plumbing. A 1/2" inlet is located on the tank to accept make-up water. A vent fitting is located on the condensate tank top for atmospheric air venting. The return fitting is to be plumbed to the trapped condensate return line coming from the process. A gauge glass and valve set are mounted on the side of the condensate tank. The tank has a ball check valve internally mounted, and a float arm and float ball assembly that serve mechanically allowing make-up water to enter the tank as the original supply is used. The pump discharge outlet is to be plumbed to the boiler check valve. The tank drain valve should be plumbed to a proper drain line. The motor is required to be wired to the boiler.

Optional Equipment

VACUUM BREAKER SYSTEMS

- For model ES boilers PN ES89369
A vacuum breaker will prevent a boiler from flooding as a result of the steam condensing internally and creating a vacuum after boiler shutdown. The breaker allows air to enter the boiler shell breaking the vacuum. This system is a must for boilers connected to a condensate return tank. The vacuum breaker consists of a spring-loaded disc and associated piping and is factory plumbed to the boiler.

AUTOMATIC BLOWDOWN SYSTEM

- Extends life of boiler
- Saves labor costs
- Starts the boiler automatically every day
- Shuts down the boiler every day
- Automatically blows down the boiler every day
- Completely programmable, can skip days, different start and shutdown times, different operational durations.
- ES81600 for all model boilers.

A stainless steel, motor driven straight-through, self-cleaning ball valve with Teflon seats handles particles and dirty fluid without the use of an up-stream strainer or other cleaning device. A timer (Standard analog time clock is set for two hour time intervals, optional digital time clock can be programmed to one minute intervals.) and electronic time delay relay control the boiler and the blowdown valve.

A pilot light indicates when the blowdown valve is open. The valve shall be plumbed to a proper drain or receptacle. An automatic blowdown system can be installed on any boiler, regardless of size operating pressure or operating duty cycle.

CONTROL VOLTAGE STEPDOWN TRANSFORMER

- Provides 120 Volt (220 Volt export) from main power supply. Factory wired and fused.

BLOWDOWN SEPARATORS (see page 17)

- For models ES12-48 - PN BDT-ASME36
- For models ES60-180 PN BDT-ASME42

A separator accepts the flash steam and effluent from the boiler blowdown and reduces the temperature and pressure to insure a safe discharge of water and sludge. Steam flash and pressure are absorbed and pass harmlessly to the outside via a vent. The separator design utilizes a water seal at the outlet, which permits the operator to introduce cold water from the bottom to mix with the hot water and boiler steam in the blowdown separator. This reduces outlet temperature to a safe discharge level.

These separators require specific plumbing from the boiler blowdown valve and require connection to a cold water supply. (If the separator is less than half full of water after the boiler is blown down cold water must be added to bring the water level to the halfway mark before the next blowdown).

- 0-30 psig pressure gauge; 0-200F temperature gauge; water sight gauge glass and valve set assembly are included.

MULTISTAGE LOAD PROGRESSIVE SEQUENCERS

Accurate control is provided by automatic progressive sequencing in the use of energy and minimizing wear on electrical components. The sequencers are designed to apply power progressively to larger KW boilers. A factory installed pressure sensitive sequential control reacting to steam boiler pressure progressive energizes or de-energizes heating elements through power contactors. A delay between sequencer steps before start-up and between each subsequent step eliminates power surges. Each sequencer is matched and factory pre-set to boiler system requirements. Electronic progressive sequencers give accurate control of multi-stage loads of the type used in steam boilers. Features include progressive sequencing (first on- first off) that equalizes the operating time of each load. Integral solid-state light emitting diodes show active stages. Should a power interruption occur, all elements are instantly de-energized for safety. Upon resumption of power the control will re-stage the loads one at a time.

Condensate Return Systems

Models 38083V & 38084V

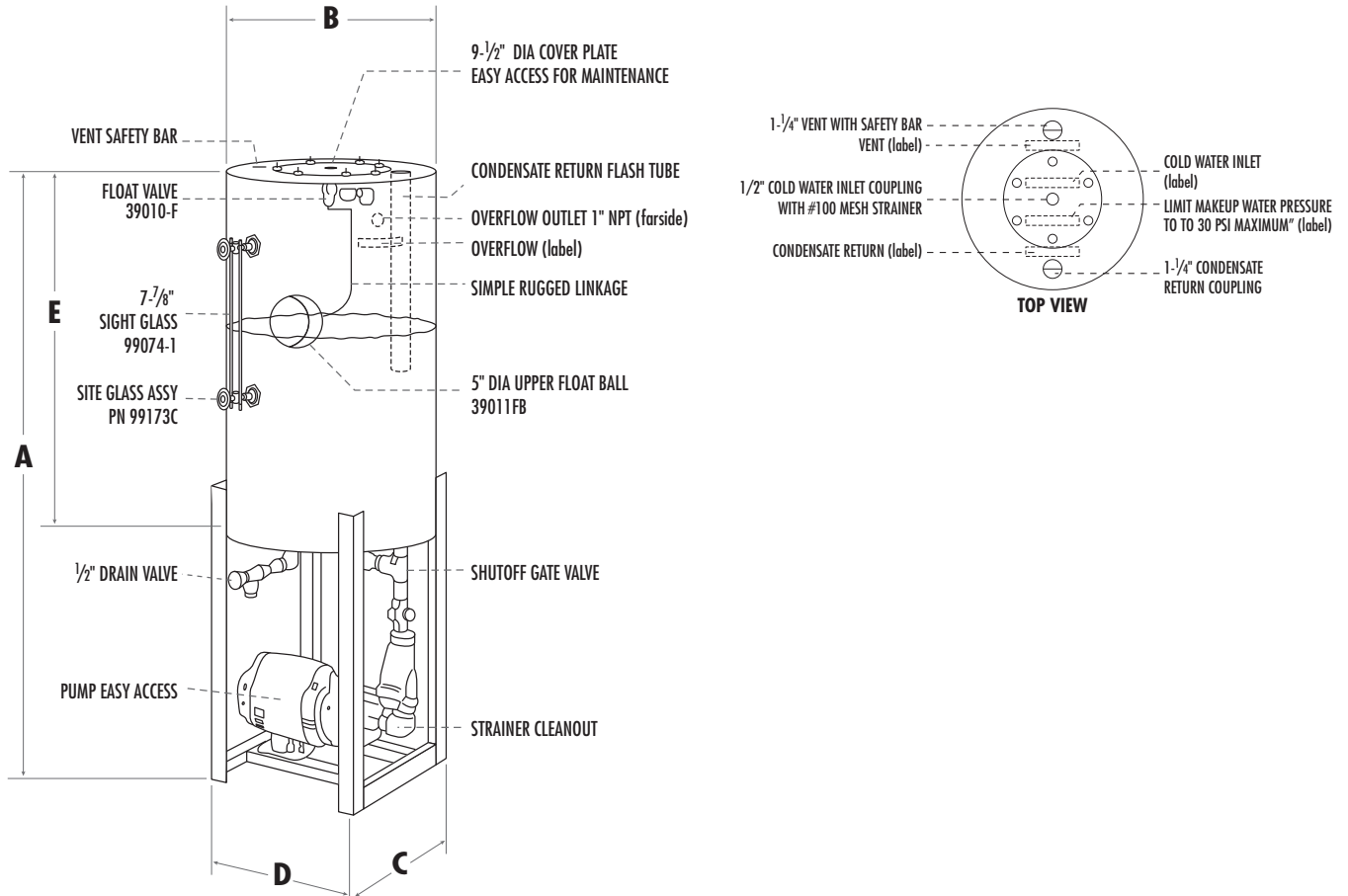

NOTES:

1. Motor/Pump is closed - Coupled design
2. Pump capacity as follows:

MODEL 38083V

PSIG	HEAD	GPM
54	125 ft.	3.2
75	175 ft.	2.9
97	225 ft.	2.7

MODEL 38084V

PSIG	HEAD	GPM
54	125 ft.	4.6
75	175 ft.	4.3
97	225 ft.	4.0

3. Normal cold water level approximately 1/2 to 5/8 up to visible part of gauge glass.

MODEL	Used on	"A"	"B"	"C"	PUMP "D"	MOTOR "E"	H.P.	VOLT/PH/HZ
38083V	ES12 - ES72	38-1/4"	18	14-1/4"	14	18	1/3	120 / 1 / 60
38084V	ES100 - ES180	51-1/2"	18	14-1/4"	14	30	1/2	120 / 1 / 60

Blowdown Separator Tanks- Specifications and Data

Models BDT-ASME 36, 42, 48, 54

Dimensions and Features

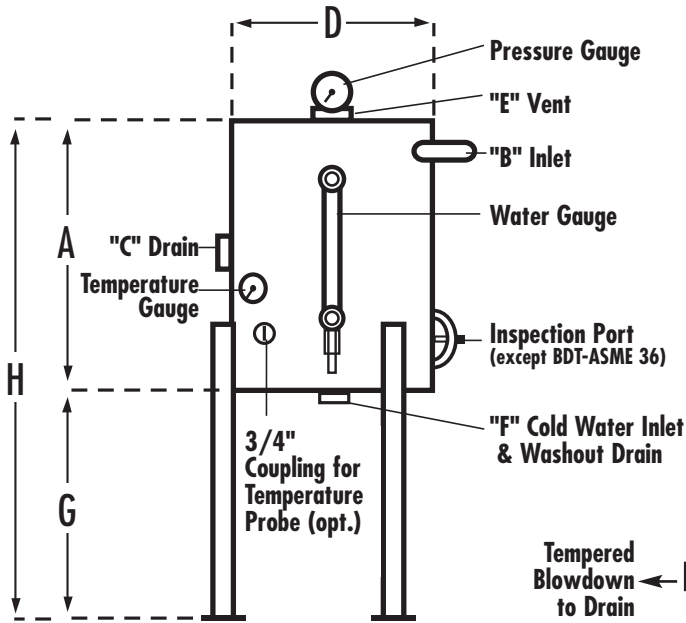

Suggested Hook-Up to Boiler

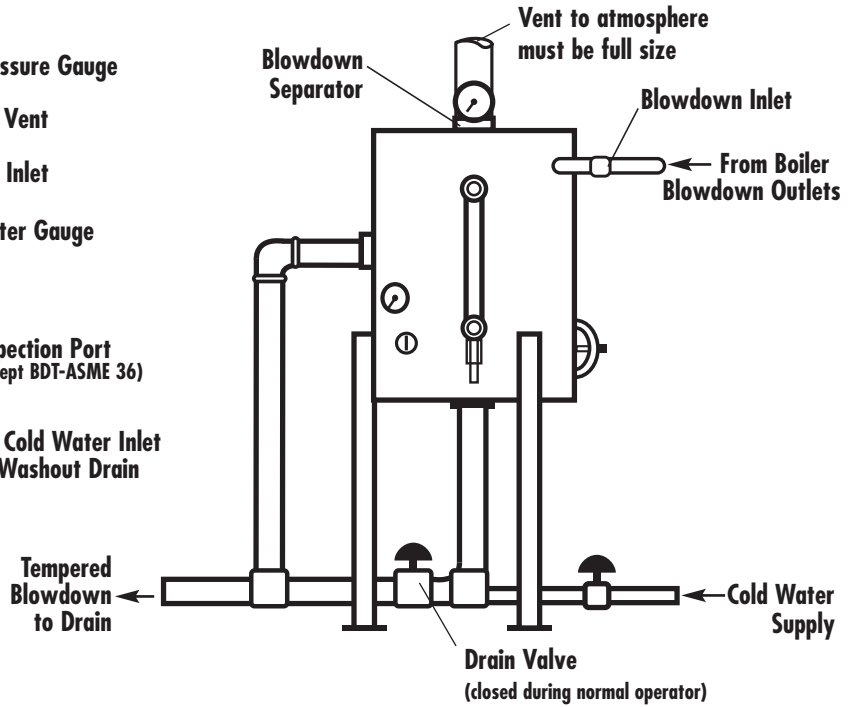

	BOILER HP	DIMENSIONS								SHIPPING WEIGHT
		A	B	C	D	E	F	G	H	
BDT-ASME 36	0-5	18"	1"	2"	12"	2"	2"	14"	32"	125
BDT-ASME 42	6-25	24"	1"	2"	16"	2-1/2"	2"	18"	42"	230
BDT-ASME 48	26-59	30"	1-1/4"	2"	16"	3"	2"	18"	48"	260
BDT-ASME 54	60-100	38"	1-1/2"	3"	16"	4"	2"	18"	54"	290

The Sussman Separator design incorporates a water seal at the outlet which permits the operator to introduce cold water from the bottom to mix with the hot water and boiler steam blowdown in the separator. This reduces the outlet temperature to a level that makes it safe for discharge.

NOTE: 1BHP is approximately 10KW.

Maximum Boiler Working Pressure: 250 psi

Maximum Blowdown Separator Pressure: 65 psi

Blowdown Separators are sized in accordance with National Board Standards

Standard Equipment

- 0-100 lb. Pressure Gauge
- 0-200° Temperature Gauge
- Water Level Gauge

Constructed in accordance with Section VII Division I ASME Boiler & Pressure Vessel Code

Specifications

Boiler Model No.	KW	Bhp Rating	Lbs/Hr Steam**	3-Ph Volts***	Amps
ES-12*	12	1.22	36.2	208 240 480	34 29 15
ES-18*	18	1.84	54.2	208 240 480	50 44 22
ES-24*	24	2.45	72.3	208 240 480	67 58 29
ES-30	30	3.06	90.4	208 240 480	84 73 37
ES-36	36	3.67	108	208 240 480	100 87 44
ES-48	48	4.90	145	208 240 480	134 116 58
ES-60	60	6.12	181	208 240 480	167 145 73
ES-72	72	7.35	217	208 240 480	200 174 87
ES-85	84	8.5	256	208 240 480	236 204 102
ES-100	108	11.2	325	208 240 480	300 260 130
ES-135	144	14.7	434	208 240 480	400 347 173
ES-160	158	16.2	475	240 480	379 190
ES-180	180	18.4	542	240 480	434 217

* Single phase available

** Steam at 212°F with 50°F feed water. See page 19 for sizing.

*** Other voltage available

Steam Gauge Pressure/ Temperature Chart

Gauge Pressure PSIG	Temperature	
	F°	C°
15	179	82
10	192	89
5	203	95
0	212	100
1	215	102
3	221	105
5	227	111
9	237	114
11	241	119
15	250	121
17	253	123
19	257	125
21	260	127
23	264	129
25	267	131
27	270	132
29	273	134
31	275	135
33	278	137
35	281	138
37	283	139
39	286	141
41	288	142
43	290	143
45	292	144
47	295	146
49	297	147
51	299	148
53	300	149
55	303	151
60	308	153
65	312	156
70	316	158
75	320	160
80	324	162
85	327	164
90	331	166
95	335	168
100	338	170

Sizing

Use the following Table to determine KW Boiler rating when steam load and feedwater temperatures are known.

Feed Water (F°)	0	2	10	15	25	40	50	75	100	125	150
40	.3347	.3355	.3375	.3388	.3406	.3422	.3431	.3447	.3458	.3464	.3470
50	.3318	.3326	.3345	.3359	.3376	.3392	.3401	.3417	.3429	.3435	.3441
60	.3288	.3296	.3316	.3329	.3347	.3363	.3372	.3388	.3400	.3407	.3411
70	.3259	.3267	.3287	.3300	.3318	.3334	.3343	.3359	.3370	.3376	.3382
80	.3229	.3238	.3278	.3271	.3288	.3305	.3313	.3329	.3341	.3347	.3353
90	.3200	.3208	.3238	.3242	.3259	.3275	.3284	.3300	.3312	.3318	.3324
100	.3171	.3179	.3199	.3212	.3229	.3246	.3255	.3271	.3283	.3288	.3294
110	.3142	.3150	.3170	.3183	.3200	.3217	.3225	.3242	.3253	.3259	.3265
120	.3112	.3210	.3140	.3154	.3171	.3287	.3196	.3212	.3224	.3230	.3236
130	.3083	.3091	.3111	.3124	.3142	.3160	.3167	.3183	.3195	.3200	.3206
140	.3054	.3062	.3082	.3095	.3113	.3129	.3137	.3154	.3165	.3171	.3177
150	.3025	.3032	.3052	.3066	.3083	.3099	.3108	.3124	.3136	.3142	.3148
160	.2995	.3003	.3029	.3036	.3054	.3070	.3079	.3095	.3107	.3113	.3118
170	.2966	.2974	.2994	.3001	.3025	.3041	.3050	.3066	.3077	.3083	.3089
180	.2937	.2945	.2964	.2978	.2995	.3011	.3020	.3036	.3048	.3054	.3060
190	.2907	.2915	.2935	.2948	.2966	.2982	.2981	.3007	.3019	.3025	.3030
200	.2878	.2886	.2906	.2919	.2937	.2953	.2962	.2978	.2989	.2995	.3001

Example: Need a boiler to produce 450 lbs. steam/hr. at 75 psig with the available feedwater temperature 50° F.
 From the chart above, find .3417 KW/Lb. of steam
 450 lbs. steam/hr. x .3417= 153.8 KW boiler required

Note: Add 20% to required kW for contingencies

Gauge Glass Installation

IMPORTANT NOTE: Read all warnings and instructions before performing installation or maintenance. Safety glasses and gloves should be worn at all times when working with or examining water gauge glass and connections. Pressure in generator to be at zero before proceeding. Improper installation or maintenance of gauge glass and connections can cause immediate or delayed breakage resulting in bodily injury and/or property damage.

1. Apply Teflon tape or pipe dope to pipe threads. Install top gauge fitting (fitting without a drain valve) into the uppermost tapping. Wrench tighten the fitting until it is snug and the glass outlet is pointing at five o'clock (about 1/8 turn from its final downward vertical position).
2. Install the bottom gauge fitting (the fitting with a drain valve) until it is snug and the glass outlet is pointing directly upward. Verify top and bottom fittings are threaded into the tappings the same number of turns (distance A= distance B).
3. Remove glass packing nut, friction washer (or packing gland, depending upon the model), and glass packing from the fittings, and place them, in the same order, on to both ends of the gauge glass. Push both packings about an inch up the gauge glass.
4. Gently insert one end of the glass into the top gauge fitting. Keeping the glass inside the top fitting, gently rotate the top gauge fitting clockwise until vertically aligned with the bottom gauge, then insert glass into bottom fitting until glass bottoms out on the shoulder inside the bottom fitting.
5. Carefully raise glass about 1/16" and slide lower glass packing down until the glass packing contacts the lower gauge fitting. DO NOT allow the glass to remain in contact with any metal!
6. Carefully slide upper glass packing up as far as possible.
7. Hand tighten both glass packing nuts, then tighten 1/2 turn more by wrench. Tighten only enough to prevent leakage. DO NOT OVER TIGHTEN! If any leakage should occur, tighten lightly, a quarter turn at a time, checking for leakage after each turn.

IMPORTANT NOTE: Read all warnings and instructions before performing installation or maintenance.

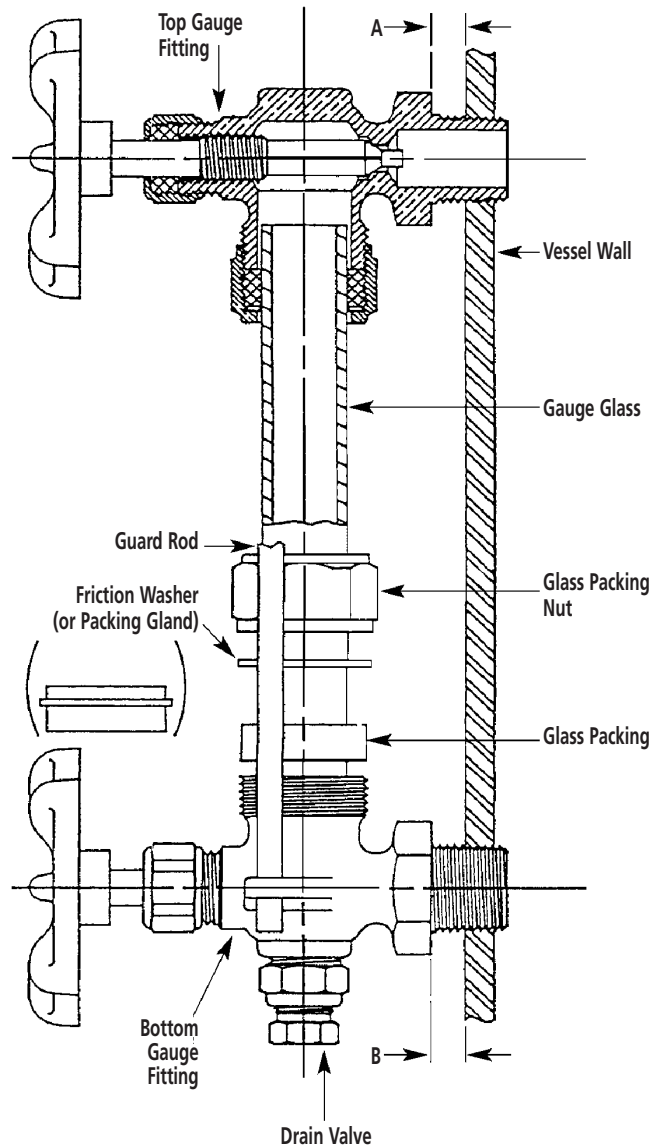

! WARNING Safety glasses and gloves should be worn at all times when working with or examining water gauge glass and connections.

Pressure in generator to be at zero before proceeding.

Improper installation or maintenance of gauge glass and connections can cause immediate or delayed breakage resulting in bodily injury and/or property damage.

Gauge Glass Installation - Use and Care

DO NOTs

- DO NOT use glass if it contains any scratches, chips, or any other visible signs of damage.
- DO NOT reuse any tubular glass or glass packings.
- DO NOT subject gauge glass to bending or torsional stresses.
- DO NOT over tighten glass packing nuts.
- DO NOT allow glass to touch any metal parts.
- DO NOT exceed the recommended pressure of the gauge or gauge glass.
- DO NOT clean the gauge or gauge glass while pressurized or in operation.

DO's

- DO verify proper gauge has been supplied.
- DO examine gauge glass and packings carefully for damage before installation.
- DO install protective guards and utilize automatic ball checks where necessary to help prevent injury in case of glass breakage.
- DO inspect the gauge glass daily, keep maintenance records, and conduct routine replacements.
- DO protect glass from sudden changes in temperatures such as drafts, water spray, etc.

MAINTENANCE

Examine the gauge glass regularly for any signs of clouding, scratching, erosion, or corrosion. The glass should be inspected daily until the need for replacement becomes apparent. This will help establish the routine inspection and routine replacement schedules.

CLEANING

Use commercial non-abrasive glass cleaners to keep glass clean. Use diluted acids such as Hydrochloric (muriatic) acid when regular cleaners do not seem to work. Do not use wire brushes or any other abrasive materials which could scratch the glass.

INSPECTION

Examine the surface of the glass for scratches, corrosion, chips, cracks, surface flaws, or nicks. To do this, shine a very bright concentrated light at an angle of about 45 degrees. A defective glass will glisten as the light strikes imperfections. Glass which appears cloudy or roughened, and will not respond to cleaning, should be replaced.

STORING

Keep gauge glass in original packaging until ready to install.

Element Replacement

READ INSTRUCTIONS COMPLETELY BEFORE STARTING WORK

CAUTION Before Installing your new elements be sure the McDonnell Miller low water cut-off and aux. low water cutoff (if supplied) is operating properly. The float chamber and lower equalizer column of the MM control must be completely clear of sludge or other foreign matter. Failure to do this may cause the immediate burn-out of the new elements. If the unit is probe equipped, check condition of the probes and isolator.

All elements are thoroughly checked before shipment The manufacturer cannot be responsible for burn-outs caused by a faulty low water cut-off.

The lower equalizer column can best be examined by breaking the unions on either side and then visually and manually examining the piping with your finger or probes to see if it is clear and clean.

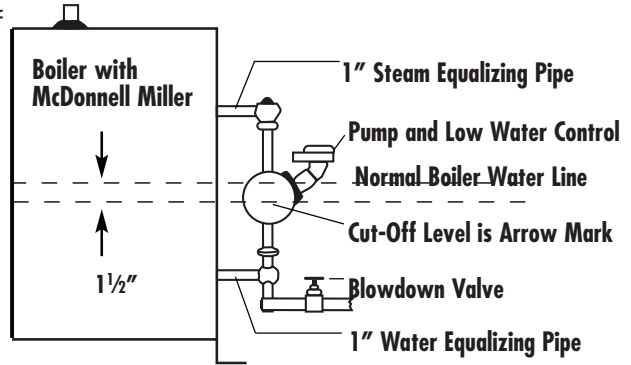

1. Disconnect boiler from electric power supply at main safety switch or fuse panel. Then turn boiler switch to "OFF" position.
2. Close water supply valve on incoming water supply line. Drain boiler completely of water.
3. Open boiler door to access heating element.
4. Disconnect wire (electric) leads connecting element to main power system of boiler. Again, note wire connections to facilitate re-assembly. Proceed to remove and discard (6) bolts from flange.

IMPORTANT: Note the wire connections to facilitate re-assembly (see wiring schematic). Remove and discard six (5/16"-18) bolts from flange. Do not reuse these bolts.

5. Thoroughly clean boiler flange of all foreign material. Be certain no part of old gasket remains on flange.
6. Apply "Slic-Tite" Gasket Compound (or equal) to both surfaces of new gasket supplied with replacement element. Proceed to install element flange assembly with gasket between boiler flange and element flange. In doing this, be careful to align flange holes so element wire connection terminals on element assembly are in line with previously disconnected wire leads to facilitate easy connections.

NOTE: Observe markings on element flange. Install element marking "TOP" on top.

7. Use only new element flange bolts. Tighten all (6) element flange bolts to a torque value of 22 lb-ft each (see illustration).
8. Connect all wires to the terminals. Tighten all element terminals to a torque value of 20 lb-in each (see illustration). Make sure all wires are clean and bright to assure good electrical contact.
9. Check that the wires are correctly connected to the contactor terminals and are tightened to the torque listed on the contactor. Make sure all wires are clean and bright to assure good electrical contact.
10. Open water valve to allow water supply to reach boiler feed mechanism.
11. As boiler automatically refills, observe the new flange assembly for possible leaks. If water is noticed, the bolts must be re-tightened. Before doing this, turn the boiler off at the main fuse safety switch.
12. When boiler reaches working pressure, check flange assembly again for leaks.

Torque Values:

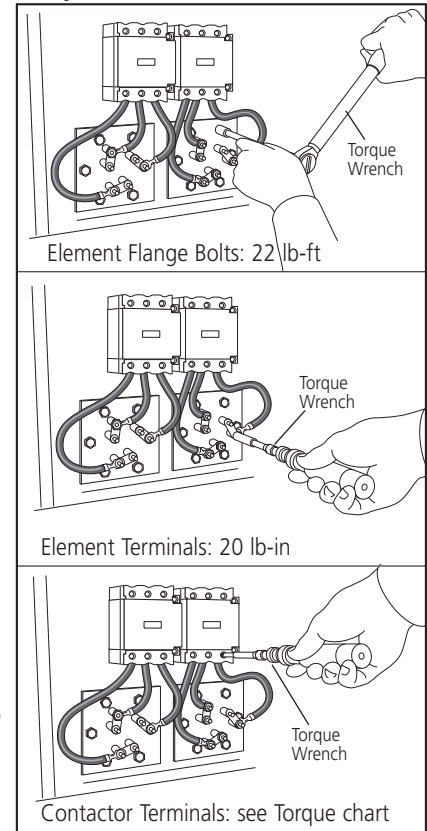

For Illustrative Purposes Only.
Power wiring shown in approximate factory-installed location

TORQUE VALUES	
Element Flange Bolts	22 lb-ft
Element Terminals	20 lb-in
Contactor Terminals:	Tighten to torque specified on contactor

CAUTION Follow maintenance instructions provided with the boiler.

Water Quality Information for Carbon Steel Boilers

For optimum results, the feedwater supply should be tested prior to initial start-up. If the mineral content exceeds the following recommended limits, various external treatment processes (water softener, reverse osmosis, etc.) may be used to correct the problem.

NOTE: An analysis of the on-site boiler feedwater must be made by a recognized and reliable water treatment company to ascertain the existing condition and treatment required.

RECOMMENDED FEEDWATER QUALITY

HARDNESS, ppm	8 – 85 (~0.5–5 gpg)
P-ALKALINITY, ppm	85 – 410 (~5–24 gpg)
T-ALKALINITY, ppm	200 – 500 (~7–0 gpg)
pH (strength of alkalinity)	8.0 – 11.4
SPECIFIC RESISTIVITY	Maximum 50k Ω cm (50,000 ohm-centimeter)

Blow down the boiler on at least a once-a-day basis. If boiler water or feed-water are outside the above limits, a more frequent blowdown is required.

Water quality can affect efficiency or result in boiler damage if neglected. Boiler feedwater contains impurities in solution and suspension. These impurities concentrate in the boiler since the steam generated is essentially pure. The concentration of these impurities increases as more feedwater is introduced into the boiler and steam is produced. If the suspended solids are allowed to concentrate beyond certain limits, a deposit or "scale" will form on the boiler's internal surfaces. This deposit can interfere with proper boiler operation and cause boiler failure.

The concentration of these impurities is generally controlled by the feedwater quality and by blowdown. Blowdown refers to removing a portion of the boiler water with high solids concentration and replacing it with make-up water of a lower concentration.



439 Main Road, Towaco, New Jersey 07082
(718) 386-6666 • 1-800-221-1522
sussmanboilers.com • Email: seb@sussmancorp.com



Designed, Engineered
and Assembled in the
★ ★ ★ ★
USA

PUR 101137 REV 5.18